

Queensland Plaza



Property Contact Information:

Address: 30 Queensland Road
 City: Stratford
 Province: ON
 Postal Code: N4Z 1H4
 Phone: (905) 612-1458
 Fax: (905) 612-8206

Property Description:

Anchor Tenants:	Sobeys	Type of Centre:	Open/One Level
Total Gross Leasable Area:	48,028 sq. ft.	Year Opened:	1990
		Number of Stores & Services:	8
		Number of Parking Spaces:	175
		Major Intersection:	Lorne Avenue and Queensland Road

Demographics:

	3 KMs	5 KMs	7 KMs
Population:	22,454	33,592	36,535
Number of Households:	9,214	13,905	14,934
Average Household Income	\$63,547	\$65,814	\$66,461

Contact Information:

Leasing Manager: Josh Katz
 Company Name: Crombie REIT
 Address: 5935 Airport Road
 Suite 810
 Mississauga, Ontario
 L4V 1W5
 Phone: (905) 671-6034
 Fax: (905) 612-8206
 Cellular: (647) 228-2345
 Email: josh.katz@crombie.ca

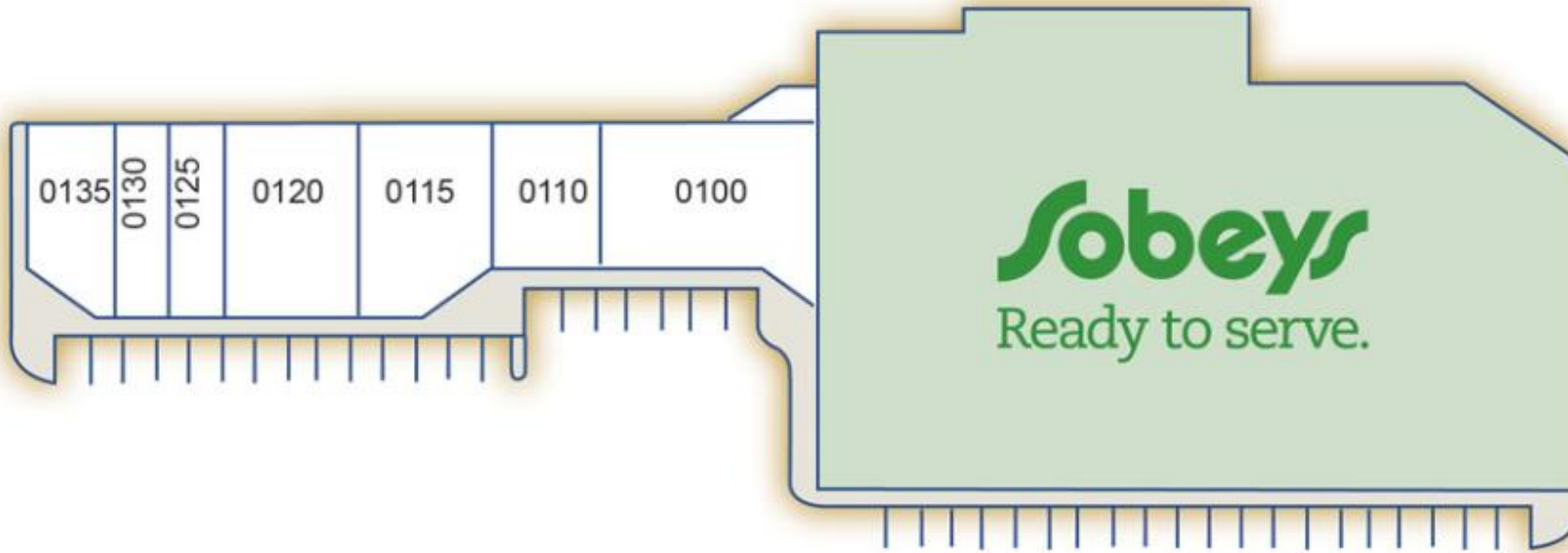

Queensland Plaza

Floor: 001

Anchor	SQ. Ft.	©
A005 Sobey's	33,070	
Ancillary Store	SQ. Ft.	©
0100 Anytime Fitness	3,726	
0110 Haircuts	1,800	
0115 Unassigned	2,500	
0120 Queensland Dollar Zone	2,993	©
0125 Tanners Sun Salon	1,000	
0130 Lai King Chinese Restaurant	959	©
0135 Dave's Diner	1,980	

Queensland Plaza

